

HIAB T-HIDUO 023



HIAB T-HIDUO 023 BASIC DATA

Technical data	HIDUO 023-2	HIDUO 023-3
Max. lifting capacity (kNm)	23,9	23,6
Lifting capacity (tm)	2,4	2,4
Outreach / lifting capacity, hydraulic extension (m/kg)	1.5/1620 2.4/1000 3.4/700	1.5/1600 2.4/980 3.4/670 4.4/520
Outreach / lifting capacity, manual extension (m/kg)	4.4/530 5.5/410	5.5/400
Outreach, hydraulic extensions (m)	1,9	2,9
Hydraulic boom extensions (m)	3,4	4,4
Outreach, manual extensions (m)	2,1	1,1
Lifting height above installation level (m)	4,7	5,7
Manual lifting height above installation level inc. Manual ext.(m)	6,7	6,7
Recommended oil flow (l/min)	10	10
Power needed at rec. oil flow (kW)	3	3
Max. working pressure (MPa)	17,5	17,5
Tank Capacity PTO (l)	18	18
Slewing angle (°)	322	322
Max. slope viable at full capacity (°)	5	5
Slewing torque, gross (kNm)	3	3
Slewing speed (°/s)	10	10
Height in folded position (mm)	1551	1551
Width in folded position static mounted (mm)	798	798
Width in folded position truck mounted (mm) no stab beam/with stab beam and tilting	1826/1926	1826/1926
Installation space needed static mounted (mm)	300	300
Installation space needed truck mounted (mm)	536	536
Weight, static mounted (kg)	270	308
Weight, mounting frame plus 2 short hydr. stabilizer legs (kg)	121	121

This table shows a few examples of models, and represents some of all options available. With the opportunity to configure your crane, we can provide you with a crane perfectly tailored to your needs.

Please contact your local dealer for more information on the variety of options we can offer.

HIAB T-HIDUO 023-2

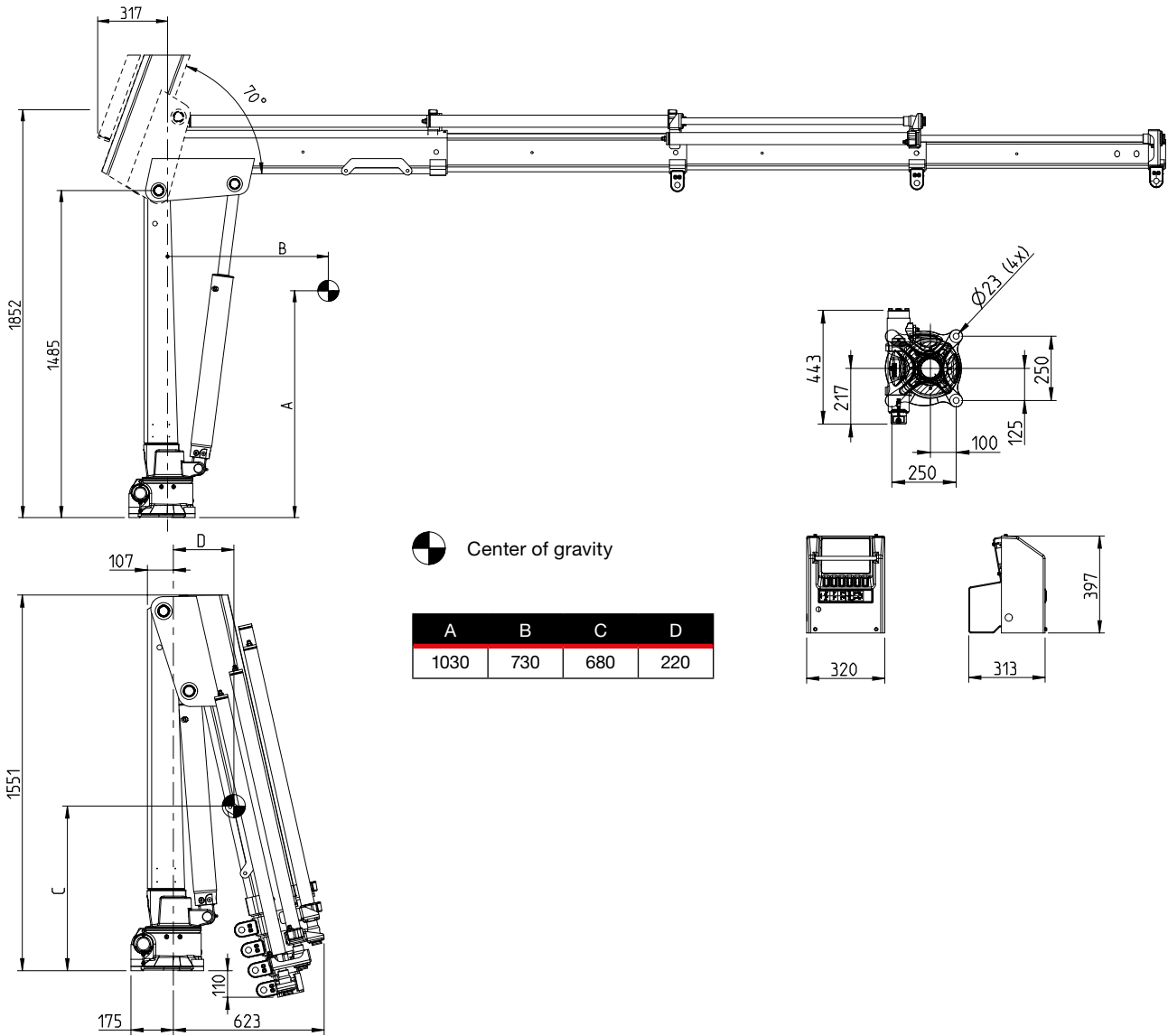

Capacity plate HIAB T-HIDUO 023-2

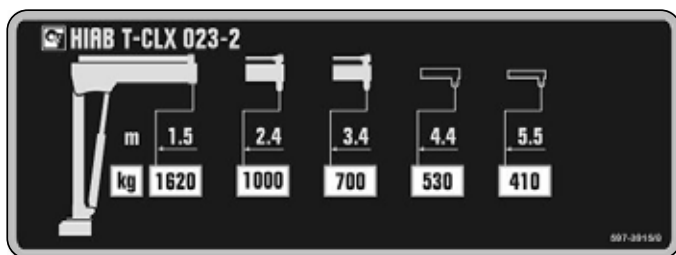

Load diagram HIAB T-HIDUO 023-2

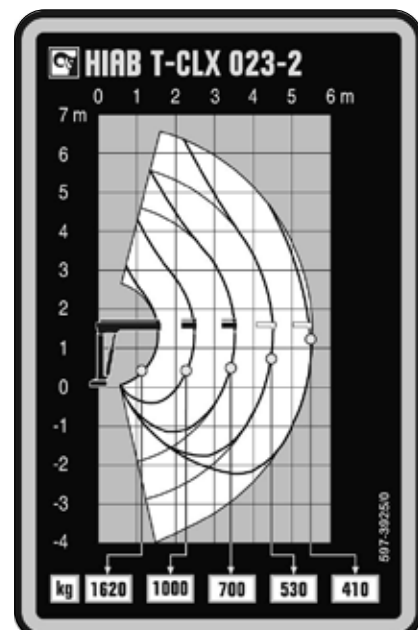

HIAB T-HIDUO 023-3

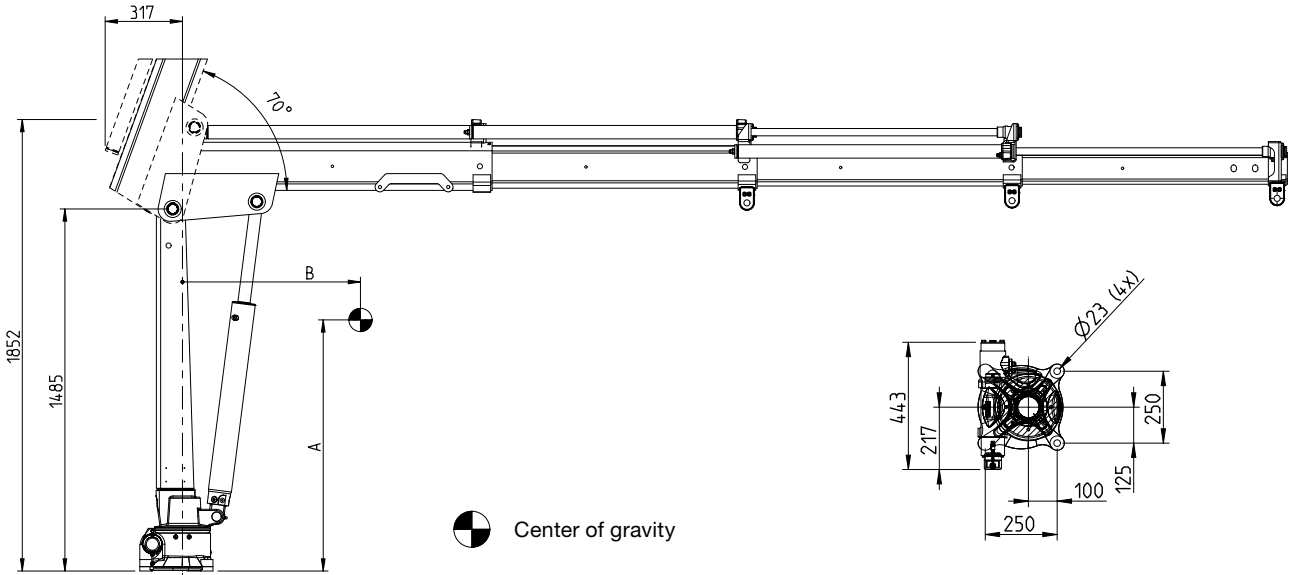

Center of gravity

A	B	C	D
1110	1100	680	260

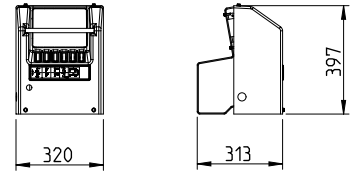
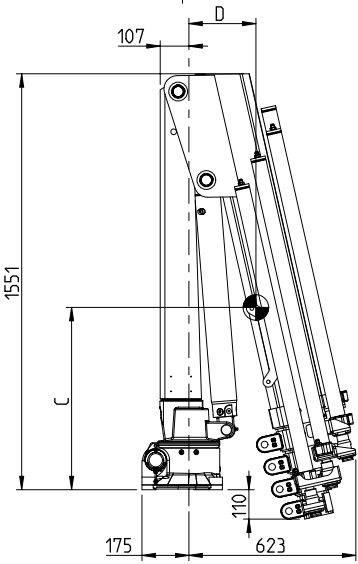

Capacity plate HIAB T-HIDUO 023-3

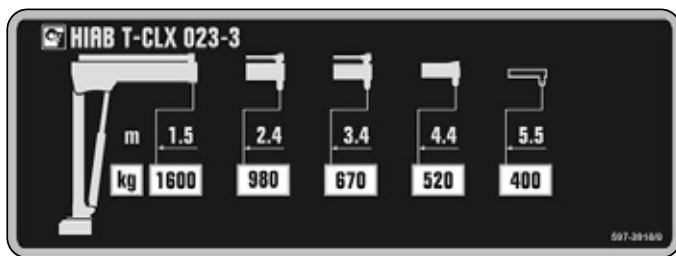

Load diagram HIAB T-HIDUO 023-3

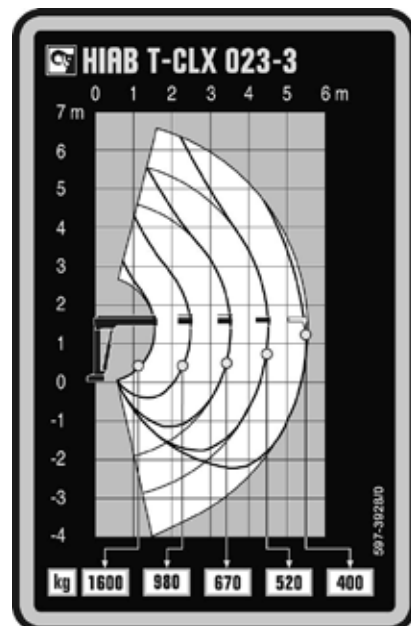

HIAB T-CLX 023

MANUAL LEG

FIXED STABILIZER

HYDRAULIC LEG

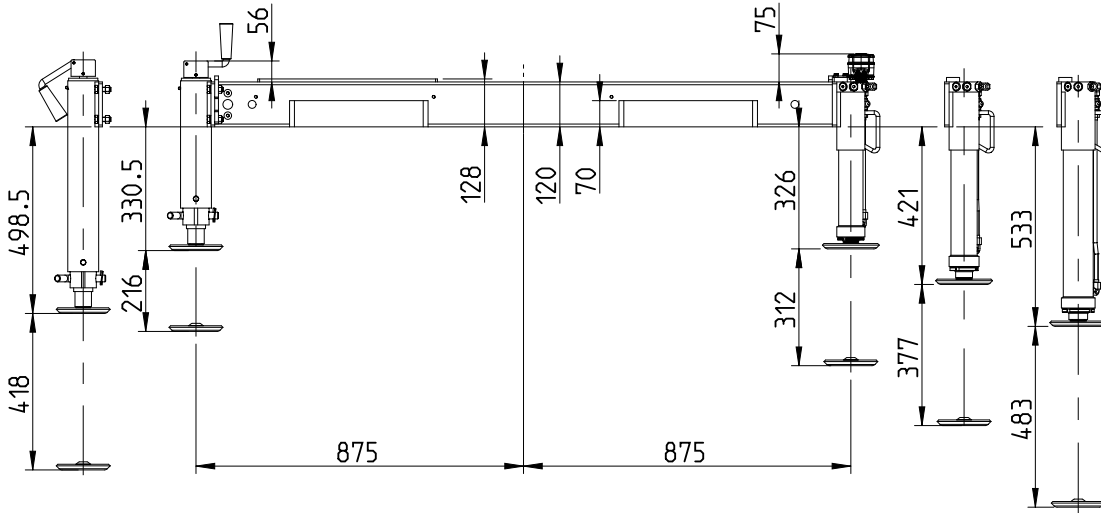

MANUAL LEG

FIXED STABILIZER WITH TILTING DEVICE

HYDRAULIC LEG

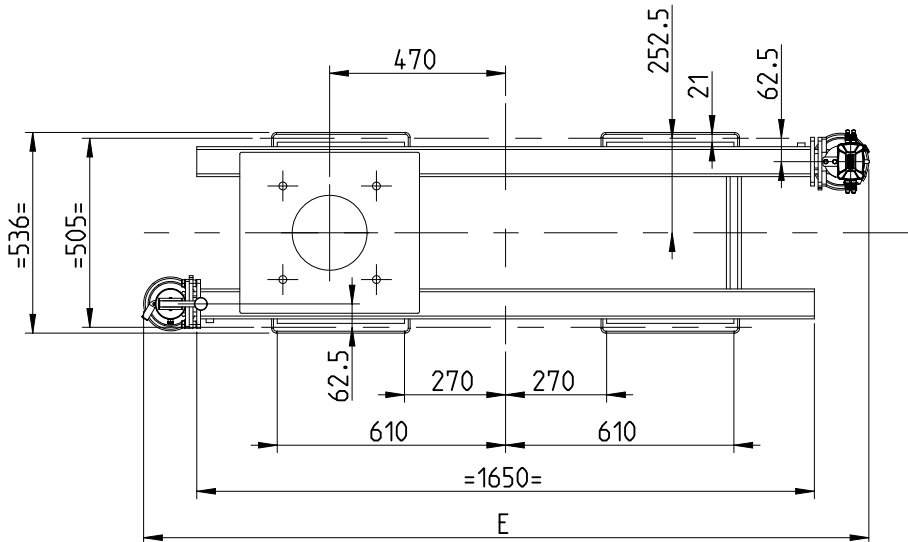
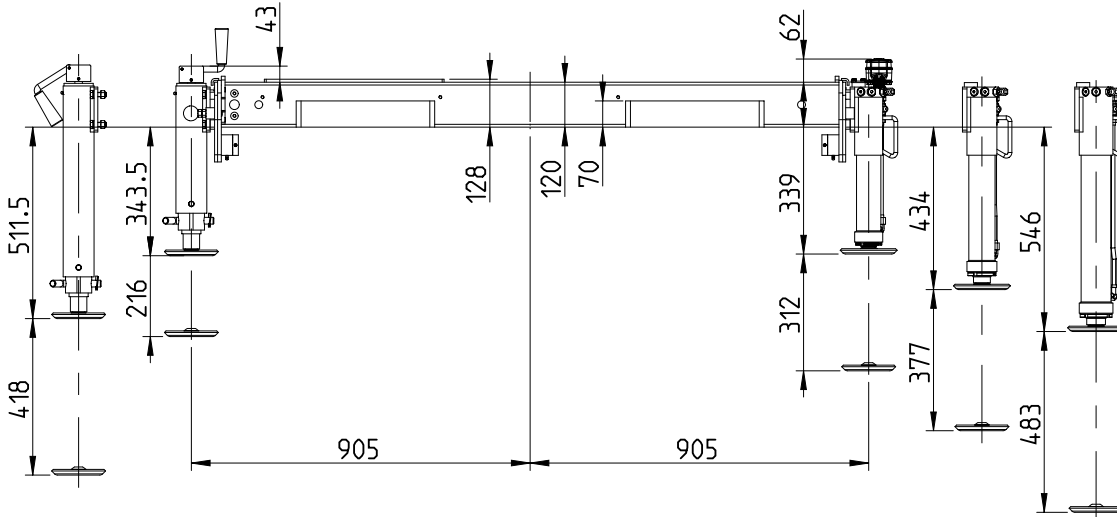

	E
Fixed	1826
Fixed with tilting device	1886
Extension	1866
Extension with tilting device	1926

HIAB T-CLX 023

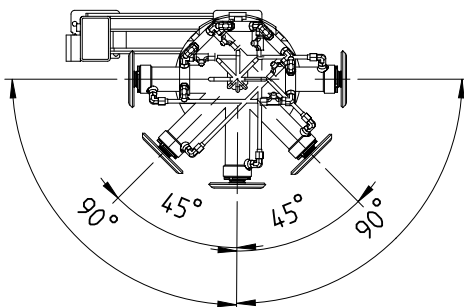
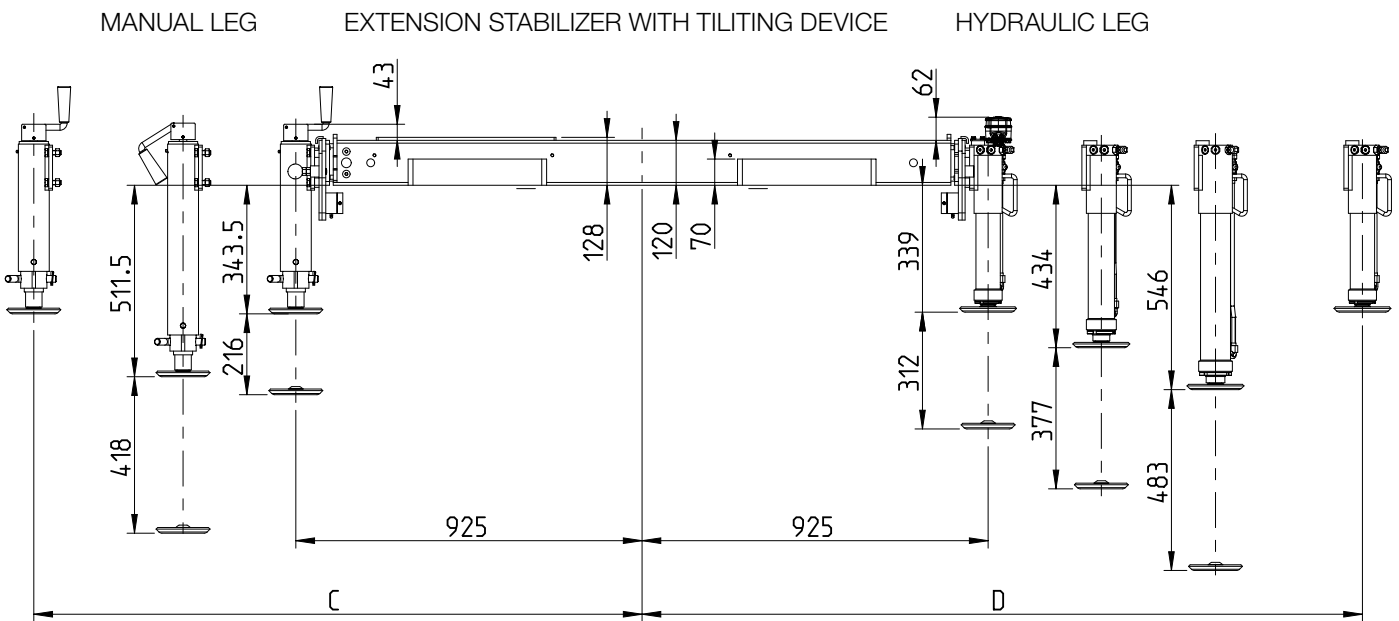
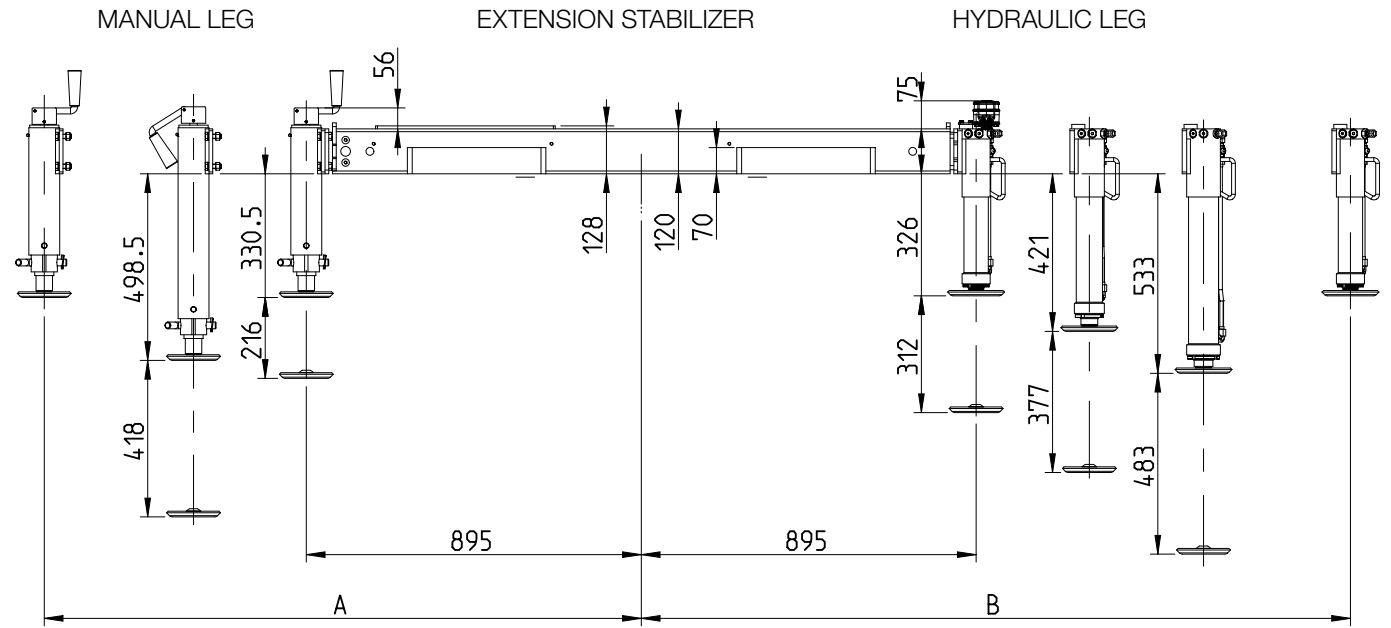

STABILIZER WITH TILTING DEVICE
PARKING POSITION

	A	B	C	D
300/300	1195	1195	1225	1225
800/800	1695	1195	1725	1225

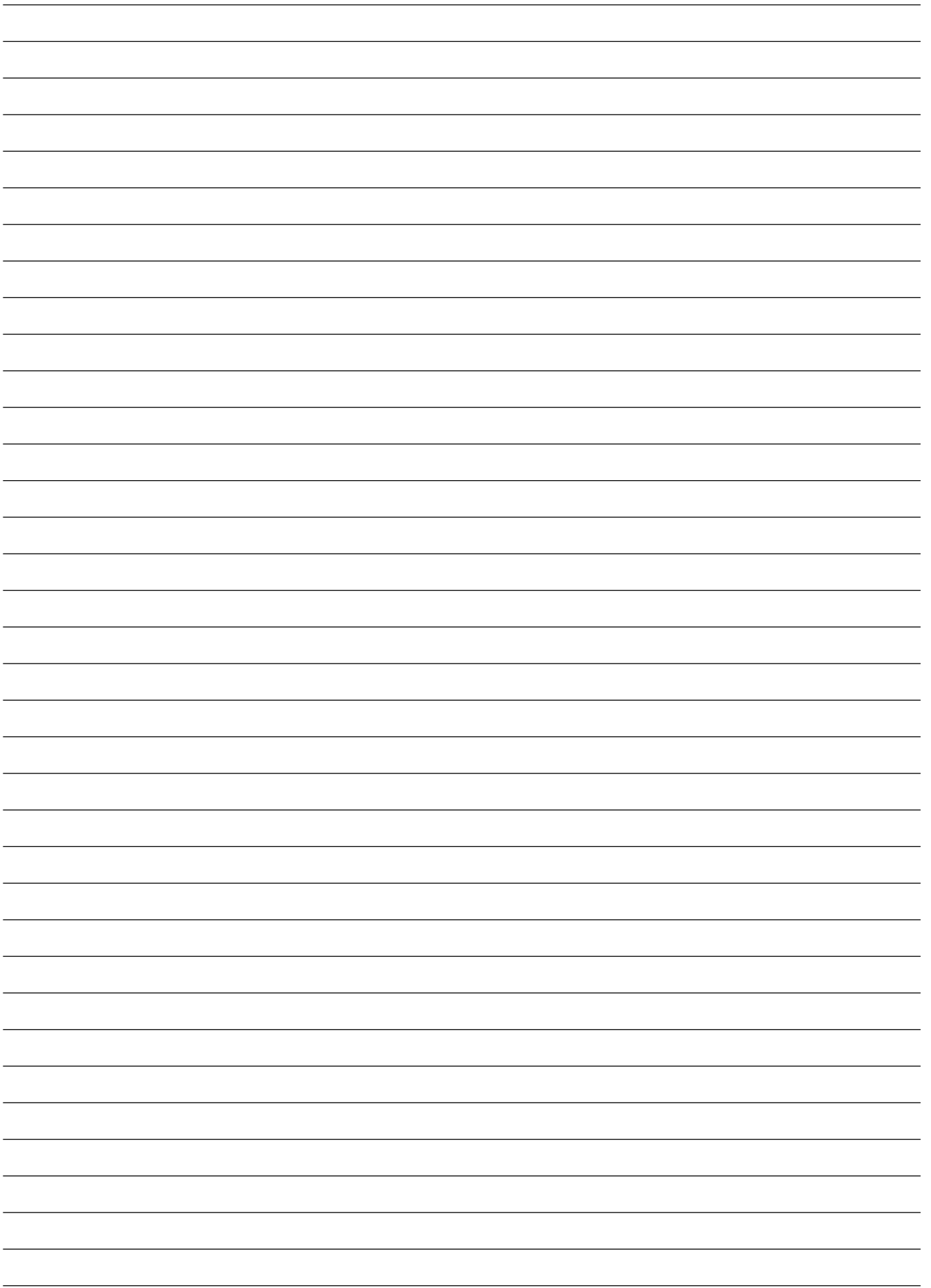

BUILT TO PERFORM

Hiab is the world's leading provider of on-road load handling equipment. Customer satisfaction is the first priority for us. Hiab's product range includes HIAB loader cranes, JONSERED recycling and forestry cranes, LOGLIFT forestry cranes, MOFFETT truck mounted forklifts and MULTILIFT demountables, as well as DEL, WALTCO and ZEPRO tail lifts.

hiab.com

Hiab is part of Cargotec.

cargotec.com

Disclaimer. We reserve the right to make changes. Illustrations, drawings and data are not always in accordance with the latest version or standard model in production. The models in the pictures may present special equipment or colours.